

SET-UP SHEET

Driver _____
Race _____
Trackname _____
Date _____

Track conditions

Surface Asphalt Outdoor Asphalt Indoor Carpet
Layout Tech Med Fast
traction Low Med High

Transmission

Gear diff oil/cst: _____ **Spurgear** _____
Gear diff oil/grams: _____ **Pinion** _____
Final drive ratio (1.9) _____

Belt width **Front** _____

Front	Shocks	Rear
_____	Spring	_____
_____	Oil	_____
_____	Piston	_____
soft (silver) <input type="checkbox"/> 3mm <input type="checkbox"/> 5mm	Internal shock spring	soft (silver) <input type="checkbox"/> 3mm <input type="checkbox"/> 5mm
med (black) <input type="checkbox"/> <input type="checkbox"/> <input type="checkbox"/>		med (black) <input type="checkbox"/> <input type="checkbox"/> <input type="checkbox"/>

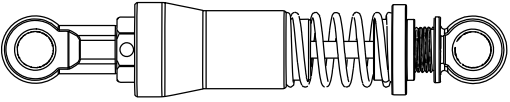
HEAVE SHOCK 
Spring _____ **Oil** _____ **Preload** _____

Front _____  **Rear** _____
Stabilizer Thickness _____
Weight balance % _____

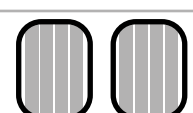
Front	Tires	Rear
_____	Additive	_____
_____	Additive time	_____
	Treated area	

Motor _____ **Timing** _____
ESC _____ **Batteries** _____
Body _____ **Wing** _____

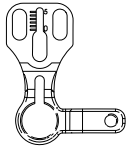
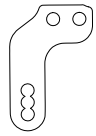
 **Ackermann setting** _____ mm
 **Steering lock inside tire** _____ degree

FRONT

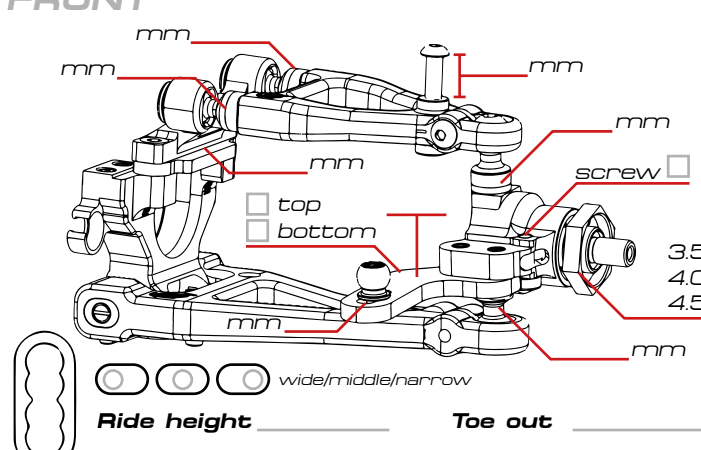

top bottom screw
 Ride height _____ Toe out _____
 Droop _____ Camber _____

REAR

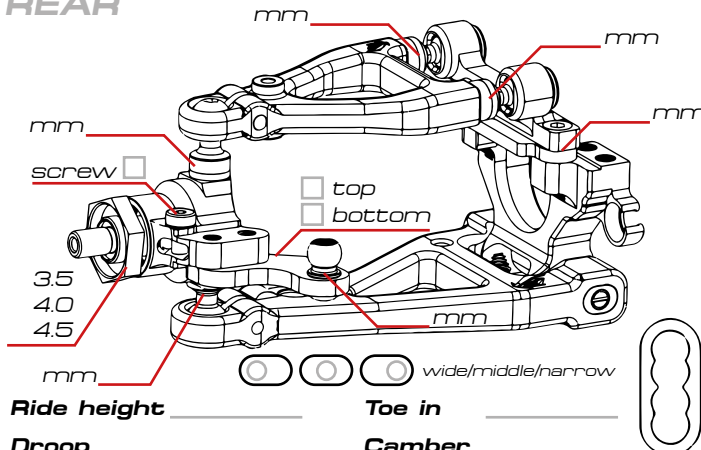

top bottom screw
 Ride height _____ Toe in _____
 Droop _____ Camber _____

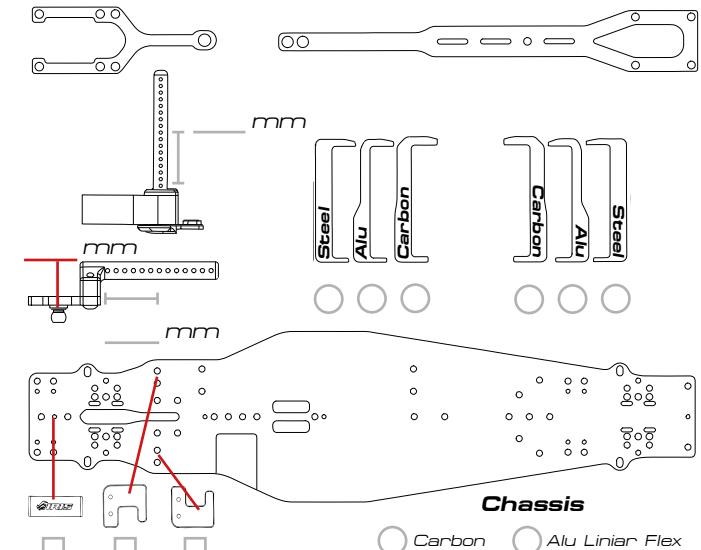

Chassis

Carbon Alu Linier Flex